

CNC

1000 Series Router

Reliable turnkey solutions for any application requiring value, performance and versatility.



MULTICAM
Complete CNC Solutions

MAXIMUM FLEXIBILITY... ...MADE AFFORDABLE

1000 SERIES ROUTER

MultiCam accepted the industry challenge to build a rigid, reliable CNC machine platform with excellent performance at an affordable price. Over 25 years of cutting edge, industry-leading design experience created the MultiCam 1000 Series Router. This machine offers a price/performance breakthrough in CNC router design.

The MultiCam 1000 Series Router provides more standard features than any other machine in its class. It's the perfect solution for any application requiring value, performance, and price in CNC router



FEATURES & SPECIFICATION GUIDE

PERFORMANCE / EASE OF USE / PRODUCTIVITY

FEATURES

No machine offers more features than the innovative and versatile 1000 Series Router.



Gantry

Engineered for Performance

The gantry is engineered for maximum stiffness from 10mm thick aircraft quality aluminum extrusion. References for the precision linear bearings and rack are engineered into the design and have excellent parallelism.



Gantry Supports

High Strength, Minimal Vibration

The gantry supports are precision machined from cast aluminum tooling plate, using a 4-Axis horizontal machining center to guarantee perpendicularity. The cast aluminum support has inherent vibration dampening characteristics while giving rigid support to the gantry tube.



Working Surfaces

Versatile, Effective, Multi-functional

The standard working surface is 1" thick 80-82 Durometer phenolic with a machined 1.5mm grid pattern utilizing .25" x .5" foam gasket tape. Phenolic makes an excellent work surface because of its dependable mechanical strength and dimensional stability.



Base Frame

Solid, Heavy-Duty Construction

The base frame is a one-piece plate steel frame that is welded, stress-relieved and precision machined. One-piece construction allows for a very accurate, rigid and smooth cutting system, while essentially removing the possibility for any after installation errors that could affect the performance and accuracy of the system.

FEATURES

No machine offers more features than the innovative and versatile 1000 Series Router.



Vacuum Pumps **Optimum Performance**

Standard vacuum pump options include an 8.5 HP (225 CFM) or 17 HP (335 CFM), two stage regenerative blower. These heavy-duty pumps will maximize material hold down and are designed for optimal performance on a wide variety of materials. Other pump options available based on application.

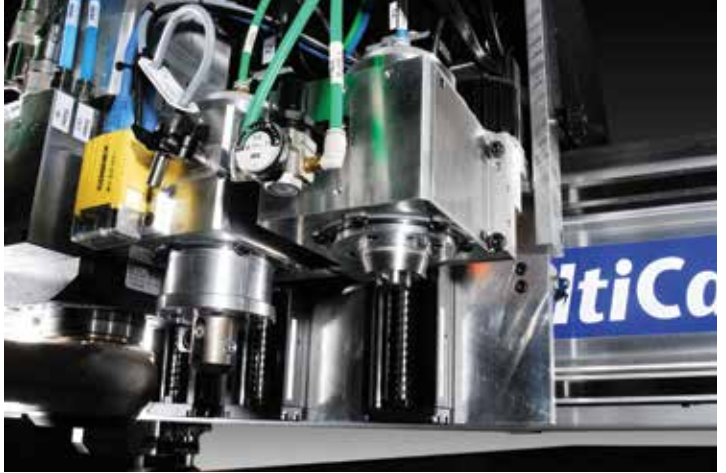

Knife Tangential Cutting System **Versatility to Meet Demand**

The MultiCam EZ Knife cartridge system is designed to perform mechanized knife cutting, creasing and perforation operations.



Linear Bearings **Fluid & Accurate**

The 25mm linear bearing profile rails with stainless spring steel strip covers are standard in the X, Y & Z axes.



Digital Stepper Drive System **Smooth & Reliable**

For the 1000 Series, MultiCam selected extensively tested two-phase, digital, brushless, synchronous electric motors. Optimized inductance and resistance of the windings provide system smoothness. Integrated digital motor drives run these motors very smoothly.



EZ Control **Easy-To-Use**

MultiCam EZ Control is one of the most powerful yet easy-to-use motion control systems available on the market. Allows for multiple job reference positions as well as automatic Z surfacing, electronic depth safety system, proximity restart and cut speed & spindle RPM override.



Router Spindles **High Speed for Increased Productivity**

The standard spindle is an air cooled, 5.5 HP ISO25, 24,000 RPM, 100% Duty Cycle spindle with a tool diameter capacity of up to 5/8" (16mm). Other available options include a 10 HP ATC spindle.



Z -Axis Assembly **Precise & Robust**

The 1000 Series utilizes a 1/2" diameter stainless steel lead screw. For high axial force loads, a precision mounting block with dual angular contact ball bearings holds it in place firmly. A brass lead screw nut carries the Z-axis load.

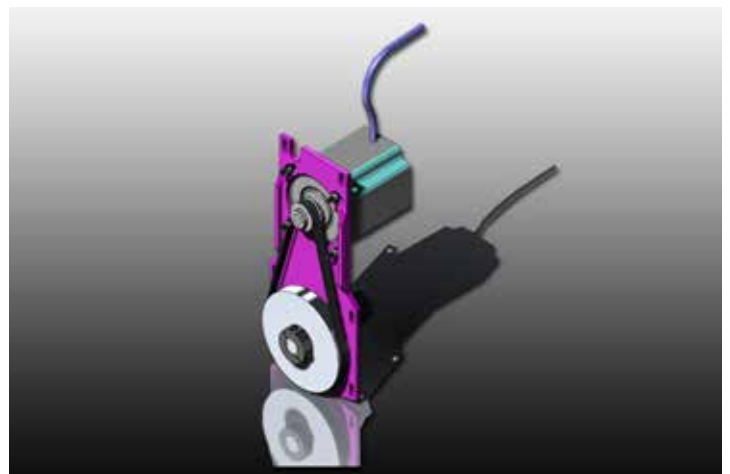

Drive Assembly **High Acceleration, Excellent Cut Quality**

Both the X and Y axes are driven by high-torque, Nema 34 stepper motor couples with 4:1 transmission assembly. This results in both good acceleration of motion as well as smooth cut quality.

OPTIONS

The 1000 Series provides a number of options to optimize your throughput and production capabilities.



MultiVision Digital Registration
Flexible & Exact



Automatic Tool Changer (ATC)
Optimized for Faster Throughput



Auto Mister
Increased Capabilities



Laser Pointer
User Friendly & Accurate

SPECIFICATIONS

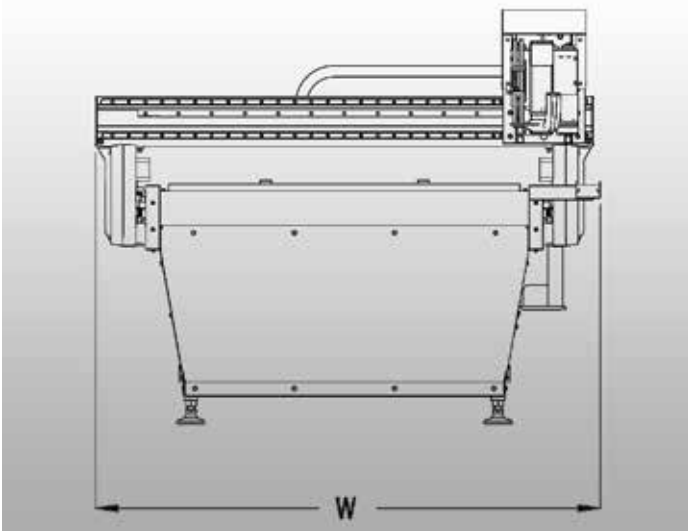
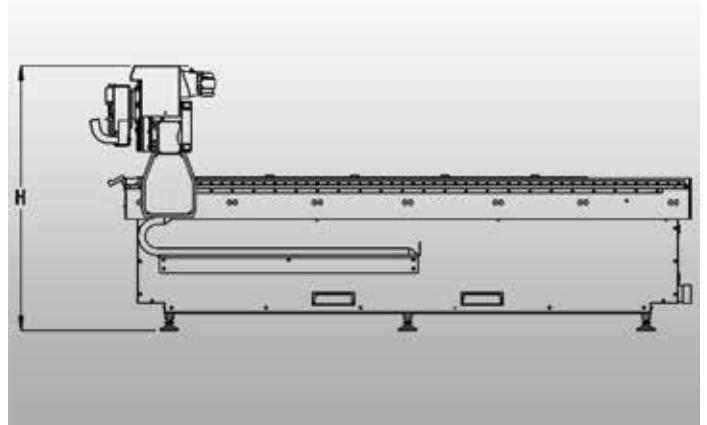
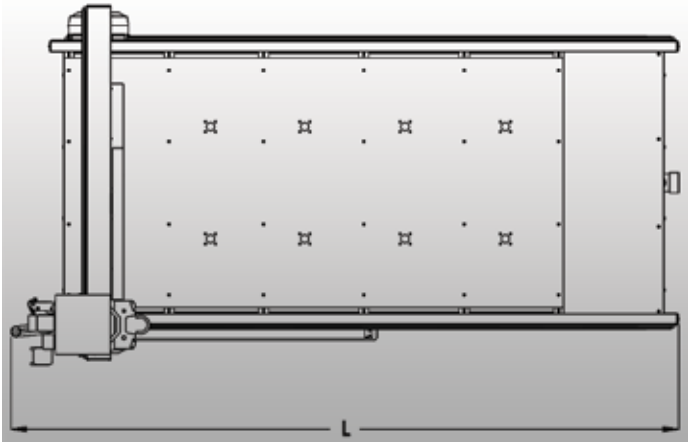

Specifications	Inches	Metric
Z-Axis Clearance	4.5"	114mm
Z-Axis Travel	6"	152mm
Slew	1130 IPM	28.702 MPM
Feed	800 IPM	20.32 MPM
Drive System (X,Y)	Rack & Pinion	Rack & Pinion
Drive System (Z)	Lead Screw	Lead Screw
Standard Work Surface	Aluminum T-Plate Extrusion	Aluminum T-Plate Extrusion

Model	L (in/mm)	W (in/mm)	H (in/mm)	Working Area (in/mm)	Weight (lbs./Kg)
1-103	155/3937	71/1803	54/1371	50 x 100 / 1270 x 2540	2612/1184
1-204	177/4495	81/2057	54/1371	60 x 120 / 1524 x 3048	3157/1431
1-205	199/5054	81/2057	54/1371	60 x 144 / 1524 x 3657	3474/1575
1-304	177/4495	101/2565	54/1371	84 x 120 / 2133 x 3048	3828/1736
1-305	199/5054	101/2565	54/1371	84 x 144 / 2133 x 3657	4193/1901
1-306	225/5715	101/2565	54/1371	84 x 170 / 2133 x 4318	4988/2262

*Other models available



MULTICAM
Complete CNC Solutions

1025 West Royal Lane
DFW Airport, TX 75261



By phone:
+1 972.929.4070
Hotline:
855.894.3136



By email:
sales@multicam.com



Or online at:
www.multicam.com